



1 COCHRANE AVE. PENNSBORO, WV 26415 PH.  
800-426-2249

**07-09 / 07-10 / 07-20**  
**STORMBREAKER PLUS 300VL**  
**IMPACT RESISTANT VINYL**  
**HORIZONTAL 3-LITE SLIDING WINDOW**  
**EQUAL LITE**

REV. #:	REVISIONS:	REVISED BY:	DATE:
1	UPDATED FOR 7TH ED. (2020) FBC	LMH	11/04/2020
.	.	.	.
.	.	.	.
.	.	.	.
.	.	.	.

**GENERAL NOTES:**

1. THIS WINDOW SYSTEM IS DESIGNED TO COMPLY WITH THE 2020 FLORIDA BUILDING CODE, INCLUDING HVHZ, AND WAS TESTED USING METHODS TAS 201, TAS 202, AND TAS 203.
2. HIGH QUALITY CAULK SHALL BE USED AROUND THE ENTIRE WINDOW PERIMETER, INSIDE AND OUT. EXTERIOR CAULKING SHALL BE CAP BEAD FOR EQUAL LEG FRAMES, OR BEHIND FINS/FLANGES FOR THOSE FRAME TYPES.
3. THE CONTRACTOR IS RESPONSIBLE FOR MAINTAINING WINDOW OPENING AND ALL WOOD FRAMING AROUND THE WINDOW.
4. WOOD BUCKS, BY OTHERS, MUST SUSTAIN ALL IMPOSED LOADS AND MUST BE PROPERLY ANCHORED TO TRANSFER LOADS TO THE STRUCTURE AND SHALL BE INSPECTED BY A BUILDING OFFICIAL. WOOD BUCK MIN. G = 0.42.
5. FOR INSTALLATION INTO CONCRETE/MASONRY, ANCHORS MUST NOT BE INSTALLED INTO MORTAR JOINTS. LOCATION SHOULD BE ADJUSTED SO THAT THE ANCHOR IS AT LEAST 2" FROM MORTAR JOINTS. CONCRETE/MASONRY SUBSTRATES SHALL CONSIST OF NON-CRACKED SOLID CONCRETE OR GROUT-FILLED CMU, 2000 PSI MIN.
6. SHIMS MUST BE USED WHEN GAP OF GREATER THAN 1/16" BETWEEN FRAME AND OPENING IS PRESENT AT THE ANCHOR LOCATION. MAX. SHIM STACK IS 1/4".
7. ONLY MIAMI-DADE COUNTY APPROVED CORROSION RESISTANT FASTENERS AND ITW TAPCON FASTENERS SHALL BE USED.
8. WINDOW INSTALLERS SHALL FOLLOW ALL MANUFACTURER'S INSTRUCTIONS.
9. NO SHUTTERS OR EXTERNAL PROTECTION DEVICES ARE REQUIRED.
10. GLAZING INDICATED HEREIN COMPLIES WITH ASTM E 1300.

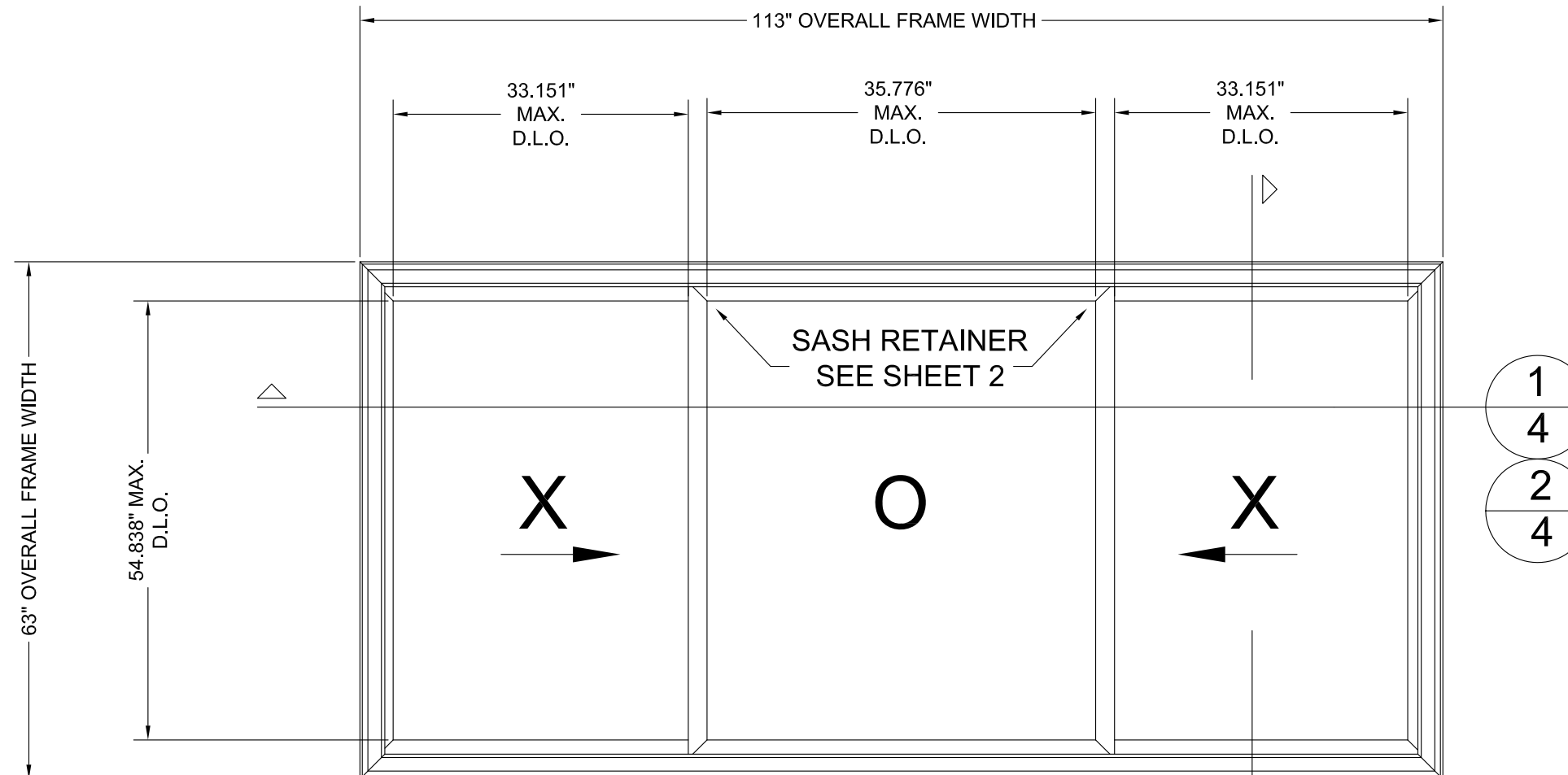

DESIGN PRESSURE RATING	IMPACT RATING
+50.0 PSF -50.0 PSF	LARGE MISSILE

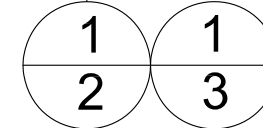
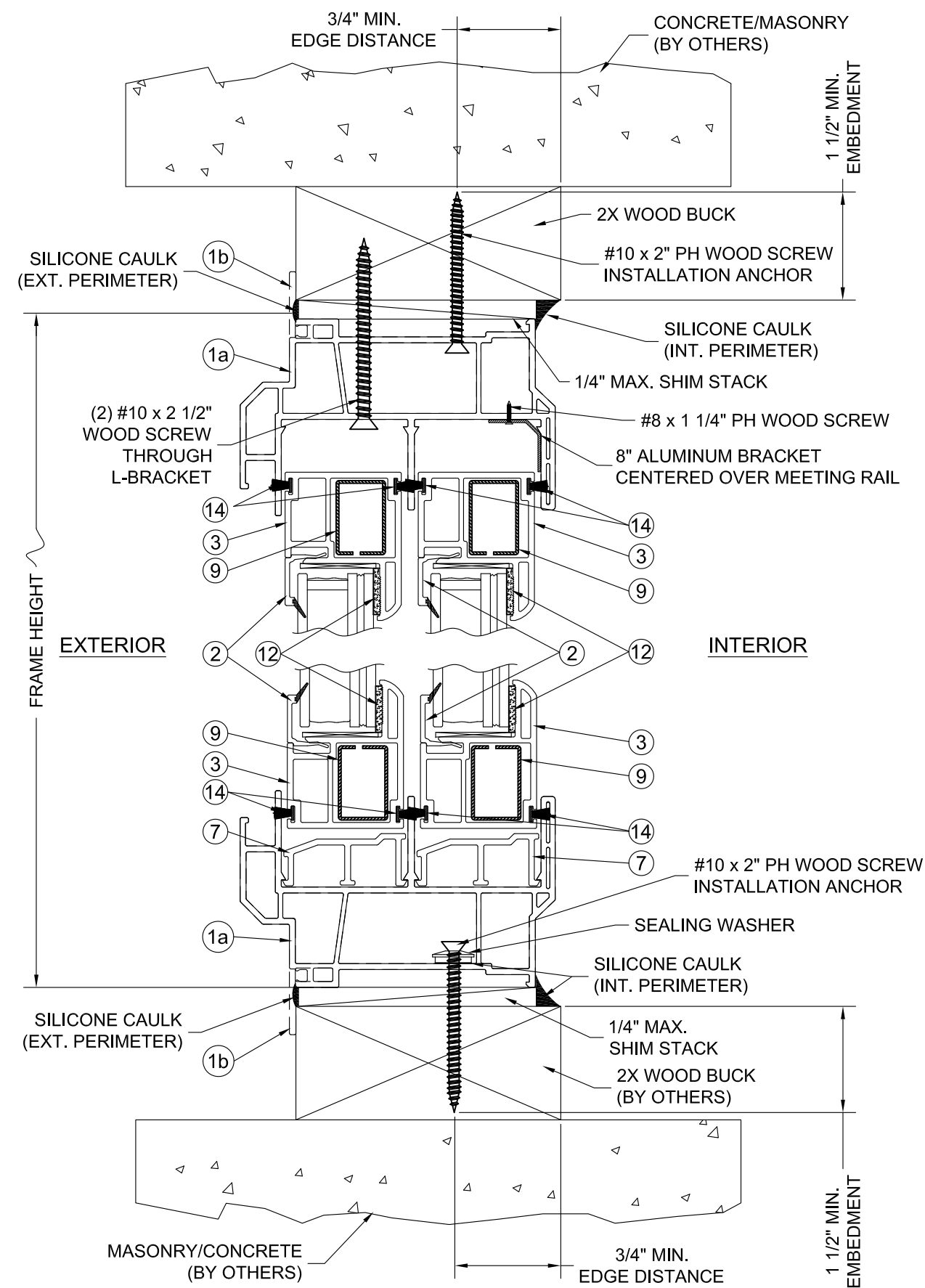

TABLE OF CONTENTS	
SHEET #	DESCRIPTION
1	GENERAL NOTES & TYPICAL ELEVATIONS
2	VERTICAL CROSS SECTIONS - 07-09 RETRO / 07-10 FLANGE
3	VERTICAL CROSS SECTION - 07-20 / NAILING FIN
4	HORIZONTAL CROSS SECTIONS - 07-09 / 07-10 / 07-20
5	ANCHORING LOCATIONS & GLAZING DETAILS (RETRO & FLANGE)
6	ANCHORING LOCATIONS & GLAZING DETAILS (NAILING FIN)
7	COMPONENTS & BILL OF MATERIALS

AS-TESTED

<p>1 COCHRANE AVENUE PENNSBORO, WV 26415</p>	SIZE: B	DRAWING NO.: DA0014	REV.: 1
	DRAWN BY: LMH	DATE: 02/01/17	CHECKED BY:
SCALE: FIT	SHEET: 1 of 7	APPR'V'D BY:	DATE:
SERIES: STORMBREAKER PLUS 300VL 3-LITE END VENT SLIDER-2X			
TITLE: GENERAL NOTES & TYPICAL ELEVATIONS			

REV. #:	REVISIONS:	REVISED BY:	DATE:
1	UPDATED FOR 7TH ED. (2020) FBC	LMH	11/04/2020
.	.	.	.
.	.	.	.
.	.	.	.
.	.	.	.



- NOTES:**
1. SHIMS TO BE A "RIGID/STIFF" MATERIAL THAT COMPLIES WITH THE REQUIREMENTS OF THE MIAMI-DADE COUNTY, FL AND FLORIDA BUILDING CODE.
  2. APPLY CAULK AROUND SCREWS AT THE SILL ONLY.
  3. REPLACE ONE L-BRACKET SCREW WITH AN INSTALLATION SCREW. (APPROX. 1 3/4" FROM CENTERLINE) IN HEAD.
  4. CORROSION RESISTANT FASTENERS AND MATERIALS THAT COME INTO CONTACT WITH OTHER DISSIMILAR MATERIALS SHALL MEET THE REQUIREMENTS OF THE FLORIDA BUILDING CODE.

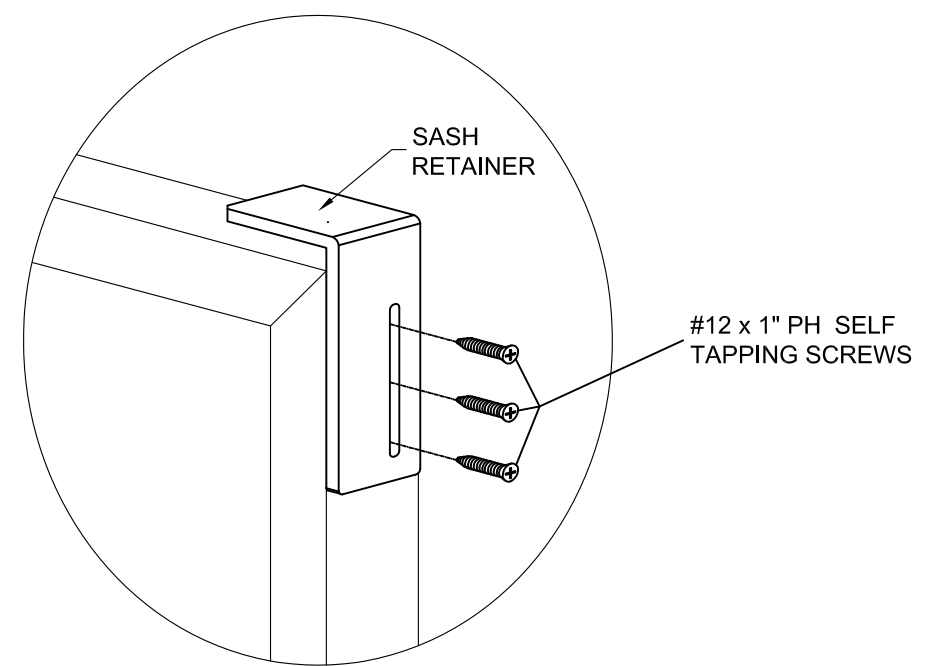

OPERATING SASH  
SASH RETAINER INSTALLATION

- 1 VERTICAL CROSS SECTION (2X BUCK)
- 2 07-09 RETRO / 07-10 FLANGE INSTALLATION

AS-TESTED

<p>1 Cochrane Avenue Pennsboro, WV 26415</p>	SIZE: B	DRAWING NO.: DA0014	REV.: 1
	DRAWN BY: LMH	DATE: 02/01/17	CHECKED BY:
SCALE: FIT	SHEET: 2 of 7	APPR'V'D BY:	DATE:
SERIES: STORMBREAKER PLUS 300VL 3-LITE END VENT SLIDER-2X			
TITLE: VERTICAL CROSS SECTIONS - 07-09 RETRO / 07-10 FLANGE			

REV. #:	REVISIONS:	REVISED BY:	DATE:
1	UPDATED FOR 7TH ED. (2020) FBC	LMH	11/04/2020
.	.	.	.
.	.	.	.
.	.	.	.
.	.	.	.

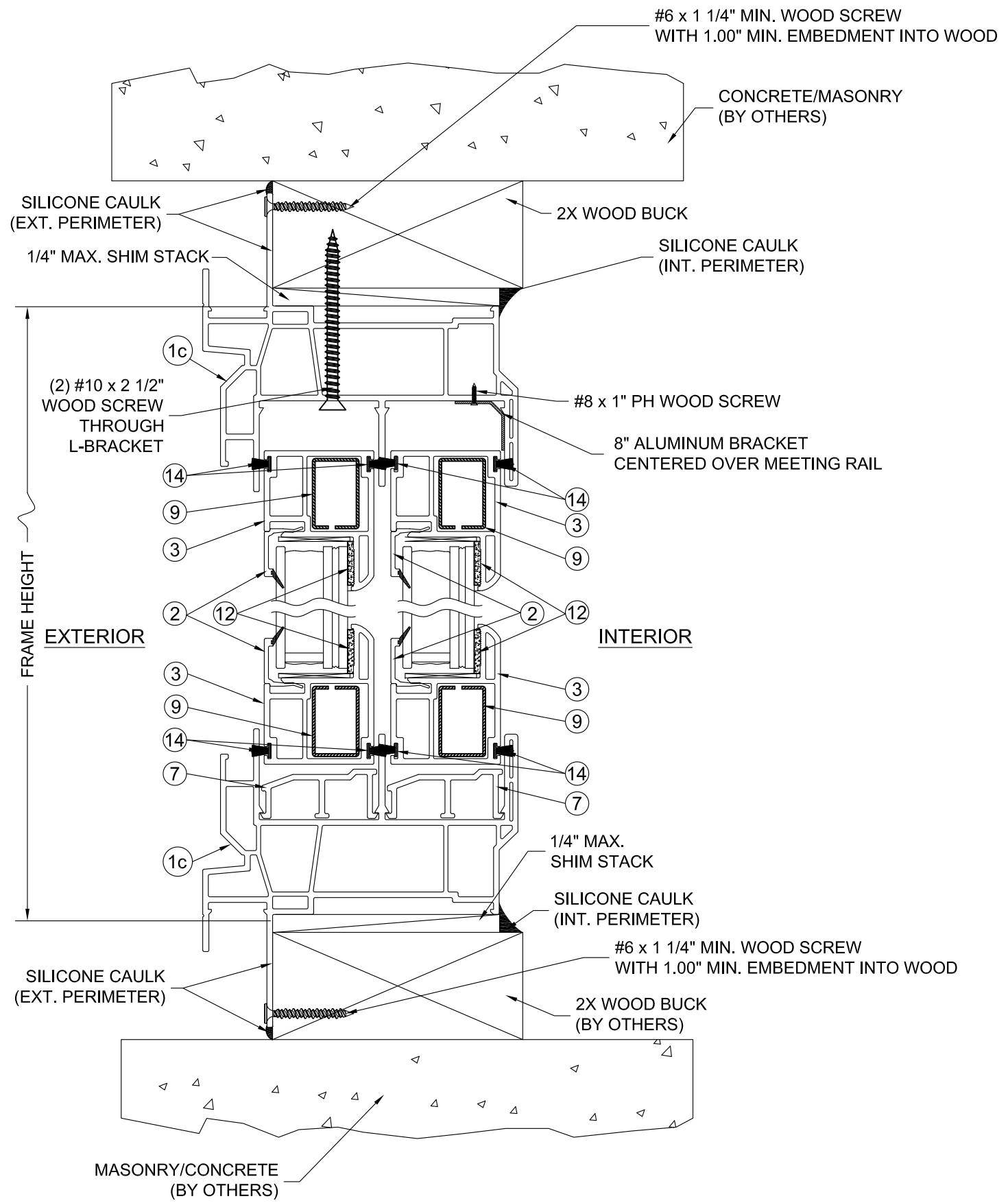

- NOTES:**
1. SHIMS TO BE A "RIGID/STIFF" MATERIAL THAT COMPLIES WITH THE REQUIREMENTS OF THE MIAMI-DADE COUNTY, FL AND FLORIDA BUILDING CODE.
  2. APPLY CAULK AROUND SCREWS AT THE SILL ONLY.
  3. REPLACE ONE L-BRACKET SCREW WITH AN INSTALLATION SCREW. (APPROX. 1 3/4" FROM CENTERLINE) IN HEAD.
  4. CORROSION RESISTANT FASTENERS AND MATERIALS THAT COME INTO CONTACT WITH OTHER DISSIMILAR MATERIALS SHALL MEET THE REQUIREMENTS OF THE FLORIDA BUILDING CODE.

1 VERTICAL CROSS SECTION (2X BUCK)  
 3 07-20 NAILING FIN INSTALLATION

AS-TESTED

 1 Cochrane Avenue Pennsboro, WV 26415	SIZE: B	DRAWING NO.: DA0014	REV.: 1
	DRAWN BY: LMH	DATE: 02/01/17	CHECKED BY:
SCALE: FIT	SHEET: 3 of 7	APPRV'D BY:	DATE:
SERIES: STORMBREAKER PLUS 300VL 3-LITE END VENT SLIDER-2X			
TITLE: VERTICAL CROSS SECTION - 07-20 / NAILING FIN			

REV. #:	REVISIONS:	REVISED BY:	DATE:
1	UPDATED FOR 7TH ED. (2020) FBC	LMH	11/04/2020
.	.	.	.
.	.	.	.
.	.	.	.
.	.	.	.

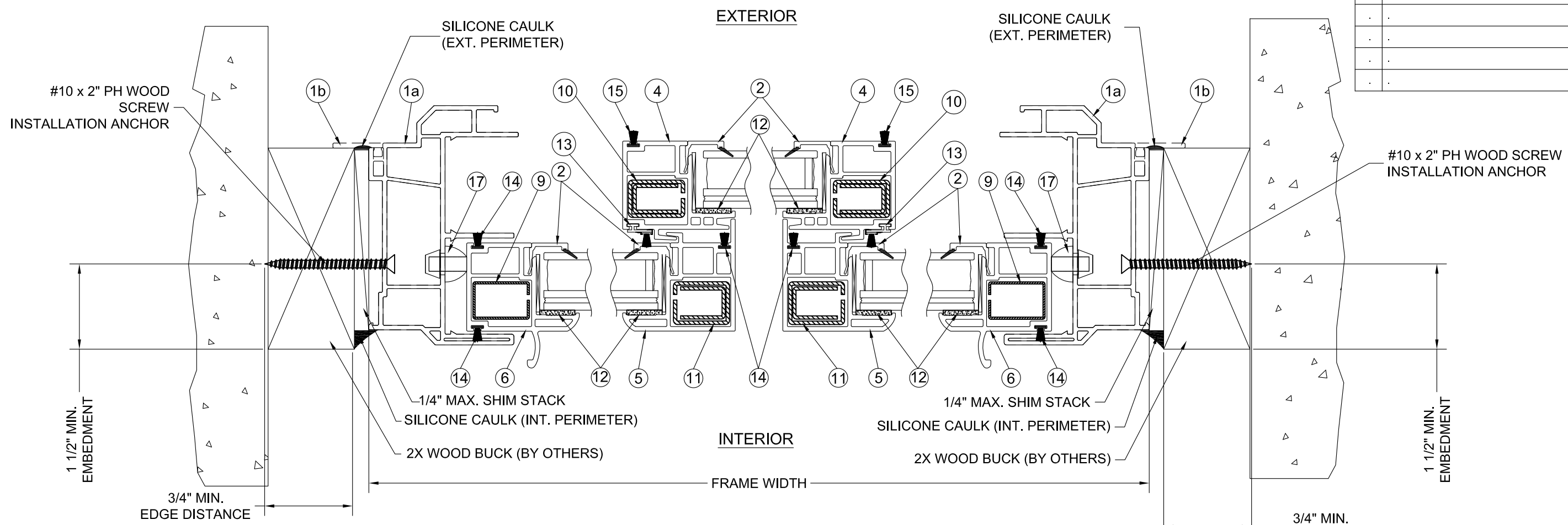

1 HORIZONTAL CROSS SECTION (2X BUCK)  
 4 07-09 RETRO / 07-10 FLANGE INSTALLATION

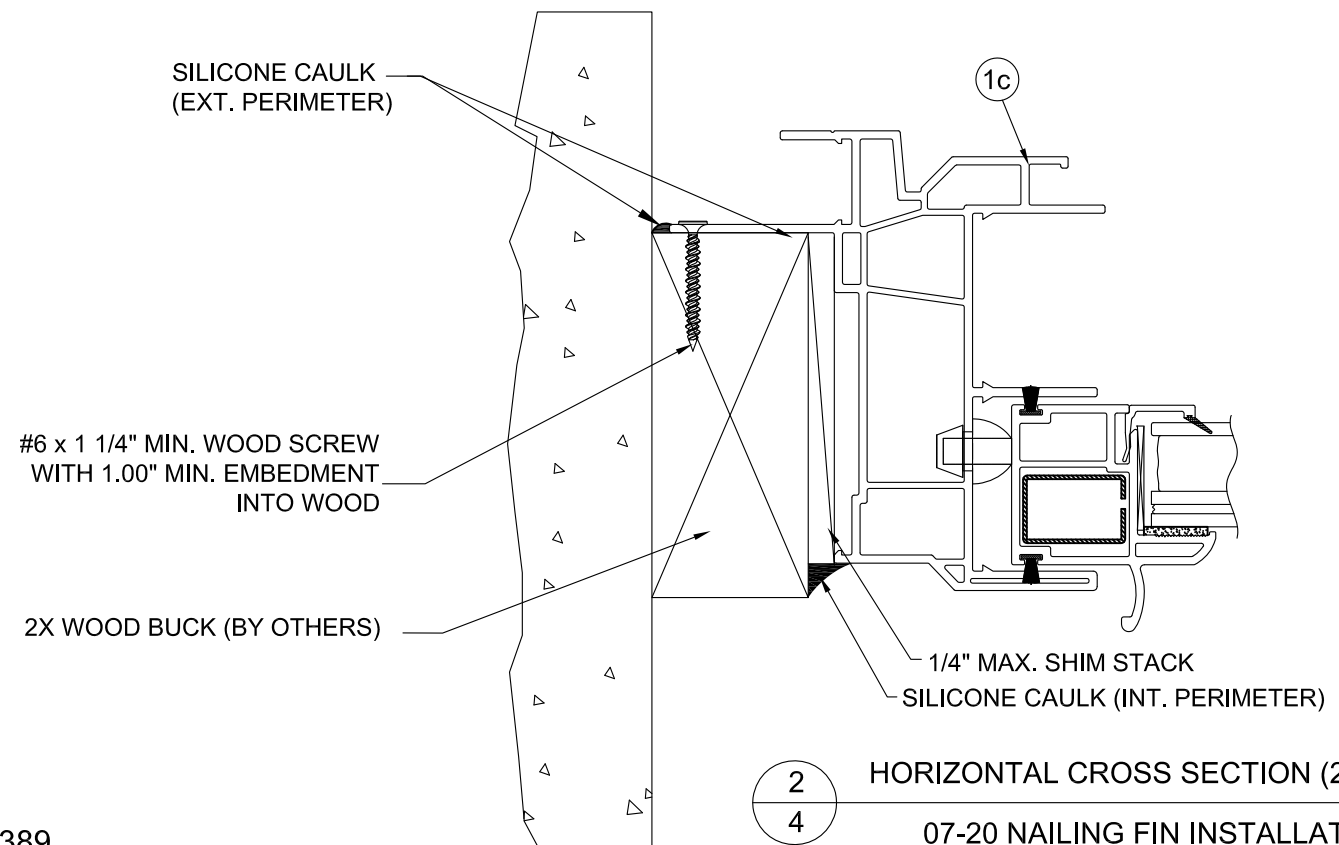

2 HORIZONTAL CROSS SECTION (2X BUCK)  
 4 07-20 NAILING FIN INSTALLATION

- NOTES:**
1. SHIMS TO BE A "RIGID/STIFF" MATERIAL THAT COMPLIES WITH THE REQUIREMENTS OF THE MIAMI-DADE COUNTY, FL AND FLORIDA BUILDING CODE.
  2. CORROSION RESISTANT FASTENERS AND MATERIALS THAT COME INTO CONTACT WITH OTHER DISSIMILAR MATERIALS SHALL MEET THE REQUIREMENTS OF THE FLORIDA BUILDING CODE.

AS-TESTED

<p>1 Cochrane Avenue Pennsboro, WV 26415</p>	SIZE: B	DRAWING NO.: DA0014	REV.: 1
	DRAWN BY: LMH	DATE: 02/01/17	CHECKED BY:
SCALE: FIT	SHEET: 4 of 7	APPR'V'D BY:	DATE:
SERIES: STORMBREAKER PLUS 300VL 3-LITE END VENT SLIDER-2X			
TITLE: HORIZONTAL CROSS SECTIONS - 07-09 / 07-10 / 07-20			

REV. #:	REVISIONS:	REVISED BY:	DATE:
1	UPDATED FOR 7TH ED. (2020) FBC	LMH	11/04/2020
.	.	.	.
.	.	.	.
.	.	.	.
.	.	.	.

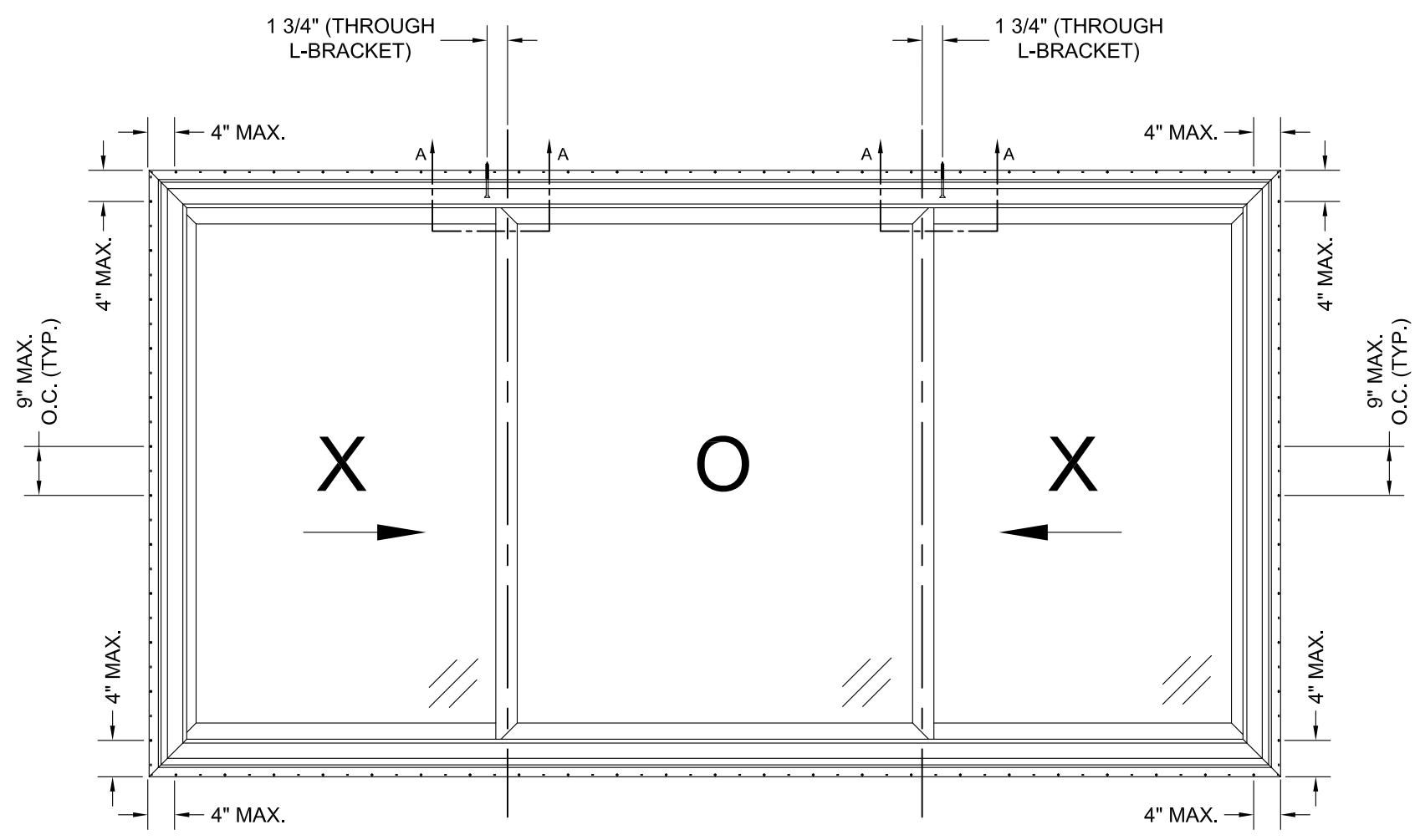

2X ANCHOR LAYOUT - 07-20 NAILING FIN  
113" x 63" HORIZONTAL SLIDING WINDOW (XOX)-EQ

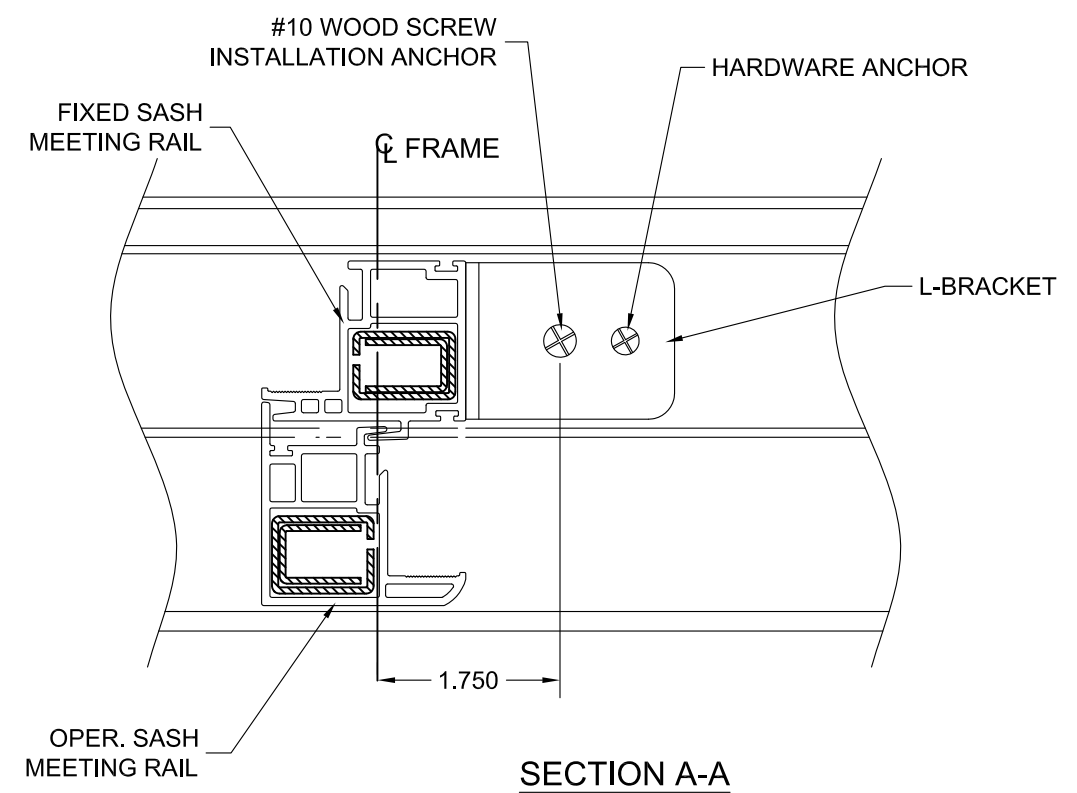

SECTION A-A  
L-BRACKET DETAIL IN HEAD

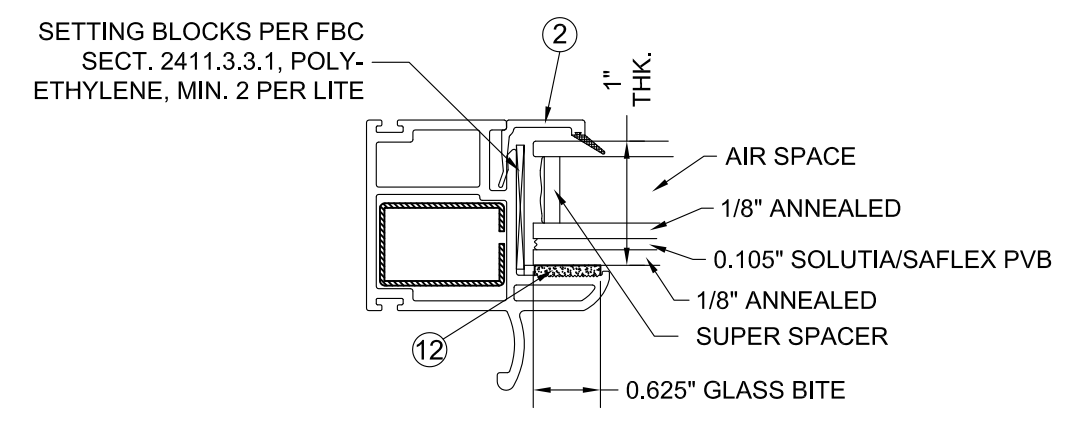

GLAZING DETAIL  
WITH SOLUTIA/SAFLEX LAMINATE

NOTES:  
1. WHEN ANCHORING WINDOW TO A 2X WOOD BUCK, USE #10 SCREWS OF SUFFICIENT LENGTH TO ACHIEVE A MINIMUM OF 1 1/2" EMBEDMENT INTO THE WOOD.

AS-TESTED

 1 Cochrane Avenue Pennsboro, WV 26415	SIZE: B	DRAWING NO.: DA0014	REV.: 1
	DRAWN BY: TDD/LMH	CHECKED BY:	DATE: 02/01/17
SCALE: FIT	SHEET: 5 of 7	APPR'V'D BY:	DATE:
SERIES: STORMBREAKER PLUS 300VL 3-LITE END VENT SLIDER-2X			
TITLE: ANCHORING LOCATIONS & GLAZING DETAILS -AS TESTED			

REV. #:	REVISIONS:	REVISED BY:	DATE:
1	UPDATED FOR 7TH ED. (2020) FBC	LMH	11/04/2020
.	.	.	.
.	.	.	.
.	.	.	.
.	.	.	.

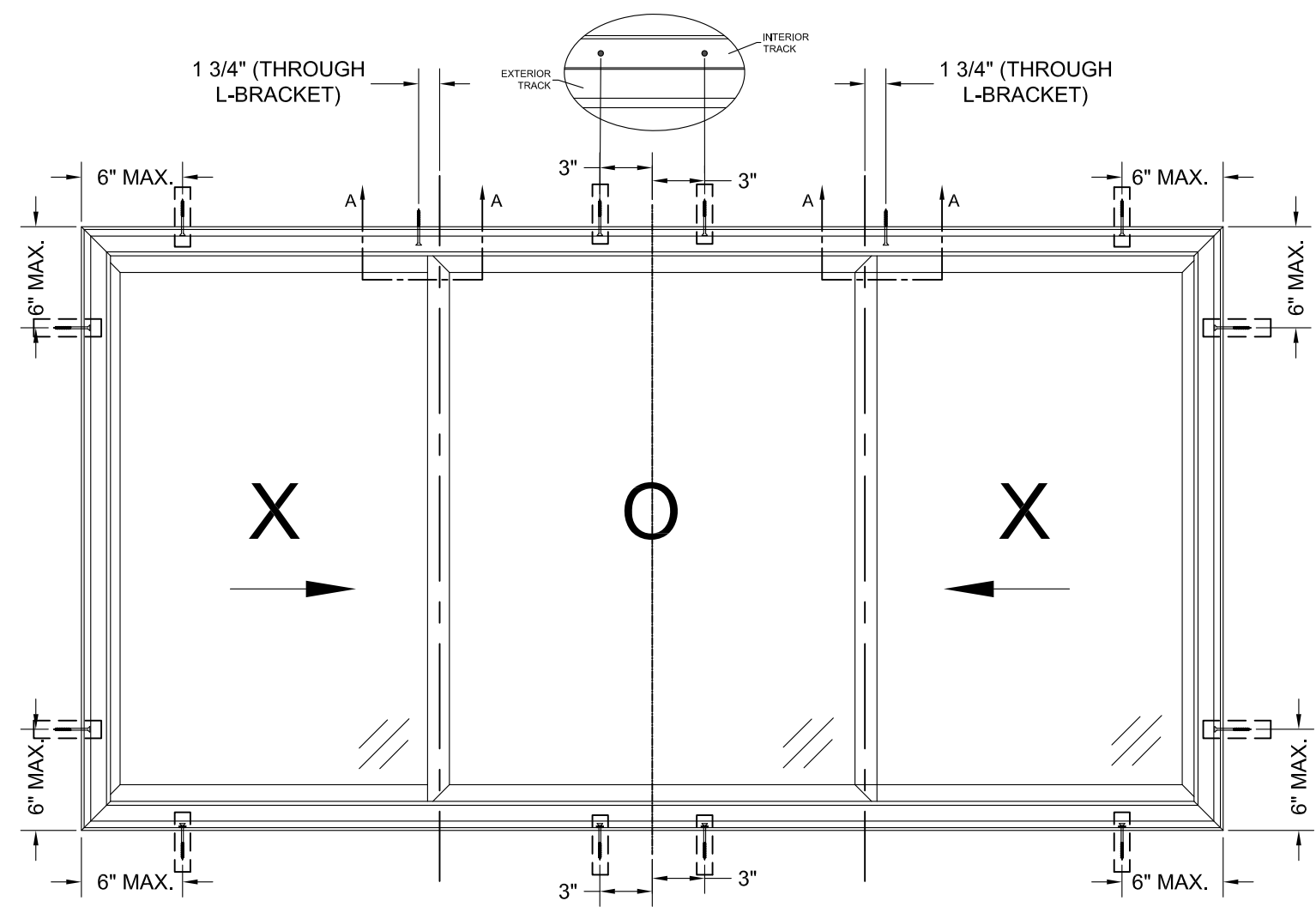

□ □ □ INSTALLATION HOLE PRE-DRILLED BY MANUFACTURER

**2X ANCHOR LAYOUT - 07-09 RETRO / 07-10 FLANGE**  
**113" x 63" HORIZONTAL SLIDING WINDOW (XOX)-EQ**

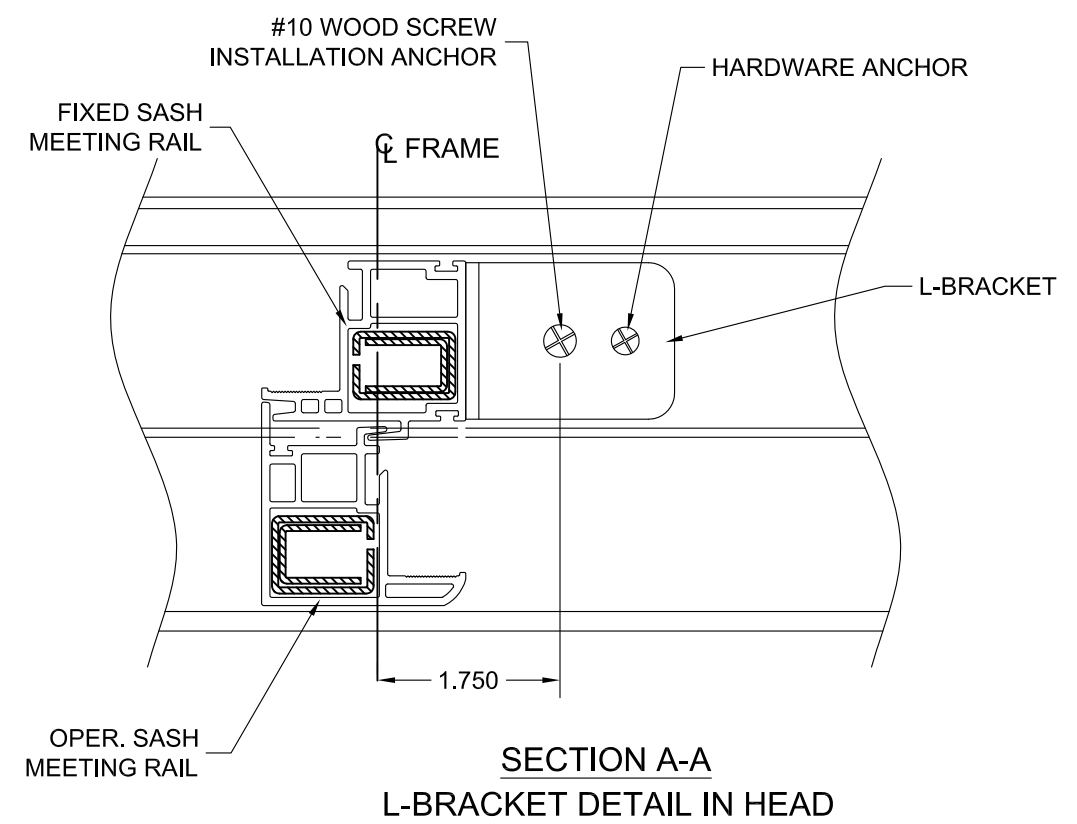

**SECTION A-A**  
**L-BRACKET DETAIL IN HEAD**

SETTING BLOCKS PER FBC  
 SECT. 2411.3.3.1, POLY-ETHYLENE, MIN. 2 PER LITE

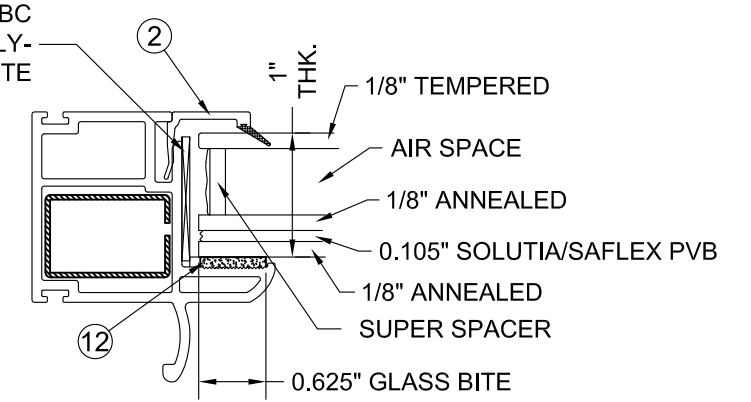

**GLAZING DETAIL**  
**WITH SOLUTIA/SAFLEX LAMINATE**

AS-TESTED

**NOTES:**  
 1. WHEN ANCHORING WINDOW TO A 2X WOOD BUCK, USE #10 SCREWS OF SUFFICIENT LENGTH TO ACHIEVE A MINIMUM OF 1 1/2" EMBEDMENT INTO THE WOOD.

FL 16389

 1 Cochrane Avenue Pennsboro, WV 26415	SIZE: B	DRAWING NO.: DA0014	REV.: 1
	DRAWN BY: TDD/LMH	CHECKED BY:	DATE: 02/01/17
SCALE: FIT	SHEET: 6 of 7	APPR'V'D BY:	DATE:
SERIES: STORMBREAKER PLUS 300VL 3-LITE END VENT SLIDER-2X			
TITLE: ANCHORING LOCATIONS & GLAZING DETAILS - AS TESTED			

BILL OF MATERIALS		
ITEM #	DESCRIPTION	MANUFACTURER
1a	SL0901S VINYL FRAME (HEAD/JAMB/SILL)	SIMEX, INC.
1b	SL1101S VINYL FRAME WITH FLANGE	SIMEX, INC.
1c	SL1201S VINYL FRAME WITH NAILING FIN/J-CHANNEL	SIMEX, INC.
2	BV18 VINYL GLAZING BEAD FOR 1" I.G.U.	SIMEX, INC.
3	SL75S VINYL COMMON SASH	SIMEX, INC.
4	SL74S VINYL KEEPER SASH	SIMEX, INC.
5	SL77S VINYL LOCK STILE	SIMEX, INC.
6	SL79S VINYL PULL STILE	SIMEX, INC.
7	V355 VINYL SILL TRACK INSERT	SIMEX, INC.
8	6063-T5 ALUMINUM L-BRACK (HEAD/SILL)	TRUTH
9	SIMRECT1 GALVANIZED STEEL REINFORCEMENT	HYGRADE
10	ST-336/ST-339 GALVANIZED STEEL REINFORCEMENT	HYGRADE
11	ST-337/ST-338 GALVANIZED STEEL REINFORCEMENT	HYGRADE
12	896-HIS GLAZING COMPOUND	PECORA
13	OFFSET FINSEAL WEATHERSTRIPPING	AMESBURY
14	0.250" FINSEAL WEATHERSTRIPPING	AMESBURY
15	0.340" FINSEAL WEATHERSTRIPPING	AMESBURY
16	0.460" FINSEAL WEATHERSTRIPPING	AMESBURY
17	PRESS FIT BUMPER STOPS	KASO
18	8" ALUMINUM SUPPORT BRACKET - HEAD	SHAPES UNLIMITED

REV. #:	REVISIONS:	REVISED BY:	DATE:
1	UPDATED FOR 7TH ED. (2020) FBC	LMH	11/04/2020
.	.	.	.
.	.	.	.
.	.	.	.
.	.	.	.

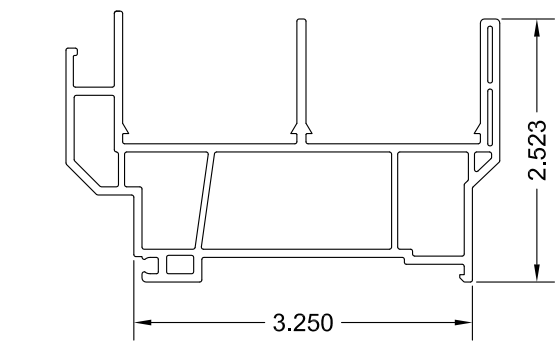

1a SL0901S  
HORIZONTAL ROLLER FRAME  
0.079" EXT. WALL THK.  
0.060" INT. WALL THK.

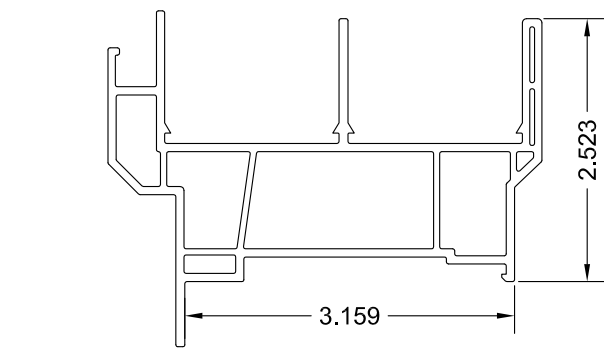

1b SL1101S  
HORIZONTAL ROLLER FRAME WITH FLANGE  
0.079" EXT. WALL THK.  
0.060" INT. WALL THK.

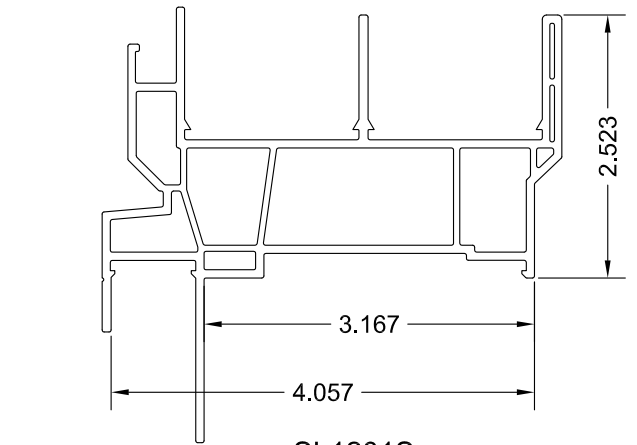

1c SL1201S  
HORIZONTAL ROLLER FRAME WITH NAILING FIN & J-CANNEL  
0.079" EXT. WALL THK.  
0.060" INT. WALL THK.

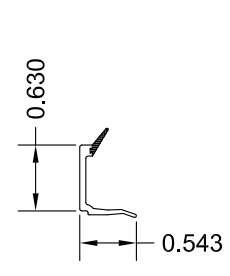

2 BV18  
GLAZING BEAD  
0.059" WALL THK.

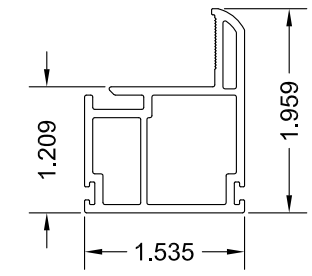

3 SL75S  
COMMON SASH  
0.079" EXT. WALL THK.  
0.059 INT. WALL THK.

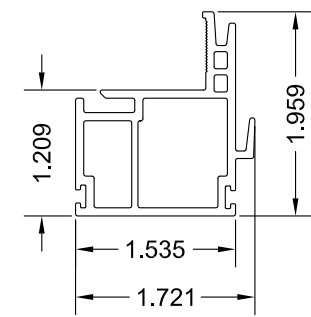

4 SL74S  
KEEPER SASH  
0.079" EXT. WALL THK.  
0.059 INT. WALL THK.

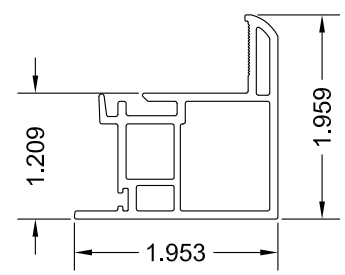

5 SL77S  
LOCK STILE  
0.079" EXT. WALL THK.  
0.059 INT. WALL THK.

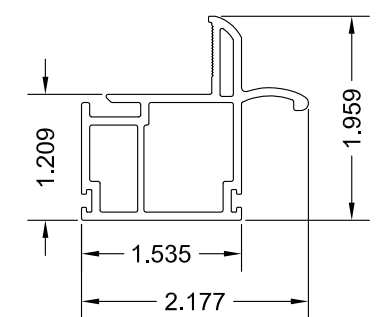

6 SL79S  
PULL STILE  
0.079" EXT. WALL THK.  
0.059 INT. WALL THK.

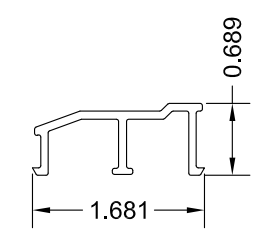

7 V355  
TRACK INSERT  
0.079" WALL THK.

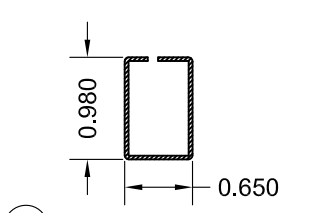

9 SIMRECT1  
RAIL/STILE REINFORCEMENT  
0.036 GALV. STEEL

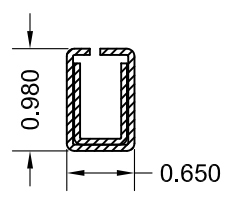

10 ST-336/ST-339  
KEEPER STILE REINFORCEMENT  
0.060 GALV. STEEL

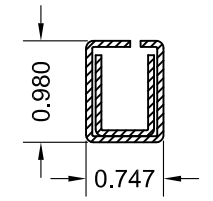

11 ST-337/ST-338  
LOCK STILE REINFORCEMENT  
0.060 GALV. STEEL



13 OFFSET FINSEAL WEATHERSTRIPPING



14 0.250" FINSEAL WEATHERSTRIPPING



15 0.340" FINSEAL WEATHERSTRIPPING



16 0.460" FINSEAL WEATHERSTRIPPING



17 SX20113  
PRESS FIT BUMPER STOPS

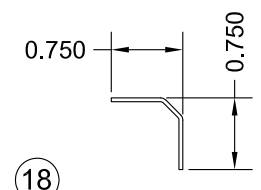

18 CM0220  
ALUMINUM HEAD SUPPORT

AS-TESTED

<p>1 Cochrane Avenue Pennsboro, WV 26415</p>	SIZE: B	DRAWING NO.: DA0014	REV.: 1
	DRAWN BY: TDD/LMH	CHECKED BY:	DATE: 02/01/17
SCALE: FIT	SHEET: 7 of 7	APPR'V'D BY:	DATE:
SERIES: STORMBREAKER PLUS 300VL 3-LITE END VENT SLIDER-2X			
TITLE: BILL OF MATERIALS AND COMPONENTS			